

OFFICE OF THE CHIEF DISTRICT MEDICAL & PUBLIC HEALTH OFFICER, DHENKANAL

RFP No- 905/ 2023-24 CDM&PHO Dhenkanal dated

**TENDER DOCUMENTS FOR SUPPLY OF IEC MATERIALS & PRINTING OF FORMS
UNDER THE ADMINISTRATIVE OF CDM & PUBLIC HEALTH OFFICER OF
DHENKANAL DISTRICT.**

Section :- 1

Date of Commencement of sale/

Available of tender documents :- 15.03.24 through website
I,e www.dhenkanal.nic.in

Date and time of sale / available of
Tender documents

:- 15.03.24 through website
i.e., www.dhenkanal.nic.in

Date and time of closing
of tender box

:- 29.03.24 till 5.30 pm

Date and time of opening
Of tender (Technical Bid)

:- 30.03.24, 11 AM

Date and time of opening
Of tender (Financial Bid)

:- same

Place of Opening of tender

:- O/O- CDM & PHO, Dhenkanal
District Head Quarters Hospital Campus
Kalikanagar, Dhakinakali Dhenkanal- 759013

Address for Communication

:- O/O- CDM & PHO, Dhenkanal
District Head Quarters Hospital Campus
Kalikanagar, Dhakinakali Dhenkanal- 759013

Email - nhmdkl@gmail.com

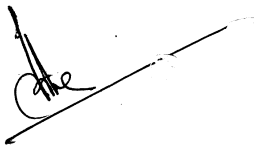

Section-I

TERMS & CONDITION FOR PRINTING OF MATERIALS

1. Sealed tenders are invited from reputed registered firms/ agencies/ dealers having adequate experience in taking up the works of printing of forms, Booklets ,poster, calendar, Leaflets, Banner, Sun board with vinyl print ,standee, Flex printing for hoarding & fixing IEC Materials, forms etc having valid GSTIN/PAN.
2. The tenderer are to submit their bids in separate sealed covered envelopes for Technical bid and Price bid by super scribing Cover "A" (Technical Bid) & Cover "B" (Price Bid) and both the sealed covers should be put into a third outer Cover, super scribed as "TENDER FOR PRINTING & SUPPLY OF IEC MATERIALS FORMS & TENDER REF NO.
3. The tenders should be addressed to
The CDM & Public health officer,
District Head Quarter Hospital,
Dist: Dhenkanal, Pin: 759013
4. All the payments are to be made through PFMS mode to the concerned party only if order of this office is available duly countersigned by CDMO/Wing officer and after submission of Bills & Photographs.
5. The decision of the Purchase committee is final and reserves all rights to go for quality testing of the goods prior to release of payments.
6. Keeping in view the budget provision the quality may not be compromised.
7. The firms will be empanelled under **ZSS Non-NRHM Account, Dhenkanal** for future course of action and bidders shall be asked to supply for goods/items/activities in future with the same term & condition beyond the current financial year o until the finalization of the fresh tender.
8. Tender must be accompanied by Rs 1,000/- Only (Non-refundable) as processing fees & Security Deposits of Rs.10,000/- by way of Demand Draft (Must be submitted), drawn on any Nationalized Bank in favour of **ZSS Non-NRHM Account, Dhenkanal**. Tenders if not accompanied by Processing fees or Security Deposit will not be considered. Security of unsuccessful bidder will be returned without interest on finalization of bid. Security of successful bidder will be retained & will be refunded after three months of completion of the activities.
9. The Average Annual Turnover of the organization must not be less than Rs.25, 00,000/- (Rupees Twenty-five lakhs) during the last three financial years (2020-21, 2021-22 & 2022-23) which shall be duly certified with UDIN No. The bidder has to submit the copy of duly certified by the Chartered Accountants with membership number.
10. Organization will have to submit IT return of last three financial years (i.e. 2020-21, 2021-22 & 2022-23).
11. The quality of the goods/services must be ensured failing which the EMD amount of the concerned bidder shall be forfeited / if payment would not have been released during the course of time then the payments shall be withheld and if any adverse remarks on the quality of the good/services has been reported then either the payment of the same with interest (as per current interest rate of the concerned bank) shall be recovered or in future any proposal/quotation/tender from the said bidder and it's organization shall not be entertained.

12. The bidders/suppliers have to submit an undertaking during supply of goods/services regarding the quality of the products on non judiciary stamp paper worth Rs.20/-.
13. The hoarding will be erected/ mounted as decided by the CDM & PHO/ADPHCO at district level and MOI/C at Block level.
14. Site selection inside the premises will be done with approval of DPHO at Dhenkanal Urban level and other places by approval of competent authority.
15. The door delivery/installation of the goods has to be taken care of by the bidders without any extra payments for the same.
16. The prices quoted must be inclusive of all charges & freight if any but exclusive GST. **Quoted rate should be maximum up to 2 decimal only.**
17. The rate will be applicable for purchase of the above mentioned items for the period of one year.
18. The bidders have to maintain office decorum during the opening and finalization of the tender otherwise the purchase committee will take its own decision as deemed proper initiating from the instant cancellation of the concerned bidder.
19. During of opening of tender only bidder himself or his authorized representatives is allowed to remain present. No authorized representative is allowed without proper authorization from bidder.
20. The time line of finalization of tender may vary or extend depending upon the emergency/ exigency of demand of the situation if any.
21. Incomplete tender shall be rejected and the undersigned reserves the right to accept or reject any or all the tenders without assigning any reason thereof.
22. All legal disputes are subject to the jurisdiction of Dhenkanal, Dhenkanal Court only.
23. The sealed tenders should reach at O/o CDMO, Dhenkanal in any working day by till 5.30 P.M along with all required documents by Speed post/Regd. post only by super scribing on the top of the envelop "**TENDER FOR SUPPLY OF IEC / BCC MATERIALS**", DHENKANAL".
24. The authority will not be responsible for the postal delay or missing of tender papers. The incomplete tender paper or received after the scheduled date and time shall not be accepted and liable to rejected.
25. Each bidder will submit only one bid.
26. Conditional Tenders (like alternative price offers etc.) are liable to be rejected. In the event of acceptance, decision of Chief District Medical & Public Health Officers will be final. The tender, which is not as per our required specifications will not be considered.
27. Printing should be as per Specification. Quality Testing (As per IS) of random samples of the printing material may be made in the Govt. Testing Laboratory & the testing charge has to be borne by the selected printing agency. The GSM of the paper specified in the technical specification should be within the tolerance limit prescribed in the related IS Standard. Any unacceptable deviation from it is liable for rejection.

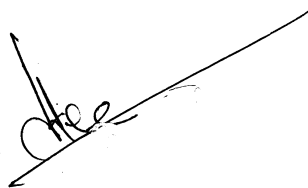

Section-II

DOCUMENTS TO BE SUBMITTED FOR PRINTING OF MATERIALS

The firm/supplier has to submit the following documents along with Technical bid (Tender Form A.)

- ❖ Photo copy of the Registration Certificate of the firm/ Agency/ Dealer.
- ❖ Photo copy of GSTIN & PAN.
- ❖ Processing fess of Rs.1,000/- Only (Non-refundable) & Security Deposits of Rs.10,000/- by way of Demand Draft (Must be submitted), drawn on any Nationalized Bank in favour of **ZSS NRHM Additionality, Dhenkanal**. Tenders if not accompanied by Processing fees or Security Deposit will not be considered. Security of unsuccessful tenderers will be returned without interest on finalization of bid. Security of successful tenderer will be retained & will be refunded after three months of completion of the activities.
- ❖ Last three year's Annual Turnover duly certified by the Chartered Accountant with Membership No. and UDIN No. (2020-21, 2021-22 & 2022-23) & Income tax return for the financial year 2020-21, 2021-22 & 2022-23)
- ❖ Copies of work order during the last three financial years (2020-21, 2021-22 & 2022-23) from the Govt. Organizations.
- ❖ Undertaking for supply of goods/services as per specification regarding the quality of the products on non judiciary stamp paper worth Rs.20/-.
- ❖ The Firm/Agency will have to submit the Affidavit on non judiciary stamp paper worth Rs.20/- with following clause:-
 - a. It has not been blacklisted by any Government Organization.
 - b. The Firm/Agency does not have any legal suit/ criminal case pending against it for violation of Act or any other law.
 - c. The authority will have no liability regarding transportation, loading and unloading of material and all the material ordered for shall be delivered at the designated place in good condition. The defective or damaged material if any will be replaced.
 - d. That the firm/agency agrees to abide by all terms & conditions of tender.
 - e. The firm/agency will quote prices inclusive of all taxes.



SPECIFICATION OF PRINTING MATERIALS

Sl no.	Name of Items	Specification
1	Hoarding (Type-1)	<p>a. Size of Hoarding : 8'x16'</p> <p>b. Quality of Surface Angle Frame to be used should be good quality.</p> <ul style="list-style-type: none"> ▪ Joist- 5"x2.5" ▪ Angle- 3"x3" ▪ Angle- 2"x2" <p>c. Three feet deep concrete on each pole of the board along with supporting Iron angle.</p> <p>d. Frame should be made from Iron Angle.</p> <p>e. Flex should be of best quality with digital multicolored printing.</p> <p>f. Flex should be fixed by Iron Pipes & GI wires.</p> <p>g. Structure of the Hoarding will be 5 feet height from ground level.</p> <p>h. The estimates per Hoarding Size 8'16'=128 sq ft should be inclusive of cost of materials tax, transportation, erection, mounting and annual maintenance cost (AMC) up to one year.</p> <p>i. The agency should quote the rate per hoarding as per size.</p>
2	Hoarding (Type-2)	<p>a. Size of Hoarding : 6'x10'</p> <p>b. Quality of Surface Angle Frame to be used should be good quality.</p> <p>c. Joist- 4"x2"</p> <p>d. Angle- 3"x3"</p> <p>e. Angle- 2"x2"</p> <p>f. Two feet deep concrete on each pole of the board along with supporting Iron angle.</p> <p>g. Frame should be made from Iron Angle.</p> <p>h. Flex should be of best quality with digital multicoloured printing.</p> <p>i. Flex should be fixed by Iron Pipes & GI wires.</p> <p>j. Structure of the Hoarding will be 5 feet height from ground level.</p> <p>k. The estimates per Hoarding Size 6'x10'=60 sq ft should be inclusive of cost of materials tax, transportation, erection, mounting and annual maintenance cost (AMC) up to one year.</p> <p>l. The agency should quote the rate per hoarding as per size.</p>
3	Change of Flex hoarding(Type-1)	Size of Hoarding : 8'x16' , Flex should be star quality, transportation, mounting
4	Change of Flex hoarding(Type-2)	Size of Hoarding : 6x10' , Flex should be star quality, transportation, mounting
5	Poster (Type-1)	Size-44cmx56cm, Process-Multi Colour (Four Colours), Paper-90 GSM Art Paper, Fixing.
6	Poster (Type-2)	Size-44cmx56cm, Process-Multi Colour (Four Colours), Paper-130 GSM Art Paper, Fixing.
7	Poster (Type-3)	Size-44cmx56cm, Process-Multi Colour (Four Colours), Paper-90 GSM Art Paper, Fixing with adhesive double side Gum tape in the back side of the poster.
8	Poster (Type-4)	Size-44cmx56cm, Process-Multi Colour (Four Colours), Paper-130 GSM Art Paper, Fixing with adhesive double side Gum tape in the back side of the
9	Leaflet (Type-1)	Size: 15.5 CM × 21.8 CM, Process: Multi colour both side printing, Paper :90 GSM art paper
10	Leaflet (Type-2)	Size: 15.5 CM × 21.8 CM, Process: Multi colour both side printing, Paper :70 GSM art paper
11	Leaflet (Type-3)	Size: 22 CM × 28 CM, Process: Multi colour both side printing, Paper :90 GSM art paper
12	Leaflet (Type-4)	Size: 22 CM × 28 CM, Process: Multi colour both side printing, Paper :70 GSM art paper

13	Leaflet (Type-5)	Size: A4, Process: Multi colour both side printing, Paper :90 GSM art paper
13-a	Leaflet (Type-5-A)	Size: A4, Process: Multi colour single side printing, Paper :90 GSM art paper
14	Leaflet (Type-6)	Size: A4, Process: Multi colour both side printing, Paper :70 GSM art paper
14-a	Leaflet (Type-6-A)	Size: A4, Process: Multi colour Single side printing, Paper :70 GSM art paper
15	Folder(Type-1)	Open Size:36 CM × 24.5 CM, Close Size: 18 CM × 24.5 CM, Process: Multi colour Paper : 90 GSM art paper, Single fold, Four Pages
16	Folder(Type-2)	Open Size:36 CM × 24.5 CM, Close Size: 18 CM × 24.5 CM, Process: Multi colour Paper : 130 GSM art paper, Single fold, Four Pages
17	Folder(Type-2-A)	Open Size:36 CM × 24.5 CM, Close Size: 18 CM × 24.5 CM, Process: Multi colour Paper : 130 GSM art paper, Single fold, 12 Pages
18	Folder(Type-2-B)	Open Size:36 CM × 24.5 CM, Close Size: 18 CM × 24.5 CM, Process: Multi colour Paper : 130 GSM art paper, Single fold, 32 Pages
19	Folder(Type-3)	Open Size:A4, Process: Multicolor, Paper : 90 GSM art paper, 2 fold, 4 Pages, Printing Both side
20	Folder(Type-4)	Open Size:A4, Process: Multicolor, Paper : 90 GSM art paper, 2 fold, 6 Pages, Printing Both side
21	Folder(Type-5)	Open Size:A4, Process: Black & White, Paper : 130 GSM art paper, Booklet contains 2 Pages, Printing Both side
22	Folder(Type-6)	Open Size:A4, Process: Black & White, Paper : 130 GSM art paper, Booklet contains 4 Pages, Printing Both side
23	Folder(Type-7)	Open Size:A4, Process: Black & White, Paper : 130 GSM art paper, Booklet contains 5 Pages, Printing Both side
24	Folder(Type-8)	Open Size:A4, Process: Black & White, Paper : 130 GSM art paper, Booklet contains 6 Pages, Printing Both side
25	Flex Banner (Type-1)	Size: 2'x 4', Solvent Printing , Fabric Media
26	Flex Banner (Type-2)	Size: 4'x 5', Solvent Printing Fabric Media
27	Flex Banner (Type-3)	Size: 4'x 6', Solvent Printing, Fabric Media
28	Flex Banner (Type-4)	Size: 4'x 8', Solvent Printing, Fabric Media
29	Flex Banner (Type-5)	Size: 3'x 6', Solvent Printing, Fabric Media
30	Flex Banner (Type-6)	Size as per requirement (Flex), Rate should be quoted per Sq.ft.
31	Bill board	Size: 10ft x 8ft, Frame: Iron Angel
32	Invitation-cum-Information Sheet	Size: 14 CM × 22 CM, Process: Multi colour, Paper :130 GSM Maplitho, Both side printing
33	Vaccination Card(certificate)/Flash Card /Patient Card(Certificate)	Size: 5 inch × 9.7 inch, Process: Multi colour, Paper: 250 GSM art paper
34	Sticker (Type-1)	Size: 14 CM × 22 CM, colour: Multi process, Paper :sticker paper
35	Sticker (Type-2)	Size: 44 CM × 28 CM, colour: Multi process, Paper :sticker paper
36	Sticker (Type-3)	Size: 12 CM × 15 CM, colour: Multi process, Paper :sticker paper
37	Foldable Standee	Foldable/Mouldable Standee Size:6X3, Strong aluminium Frame with wide base, Fabric Media
38	Display Board (Type-1)	Size: 3'X 2' Sun Board Thick Ness- 3 MM Sun Board Printing Process- Eco Solvent Vinyl Print Process- Multi colour □ The hoarding is inclusive of material cost, transportation, erection, mounting at different hospital of Dhenkanal district, ward waiting space.
39	Display Board (Type-2)	Size 3'x2' Iron Gauze bar 20 gauze 1"x2" / printing message on flex & fasting them/ print quality frot lit fle- fixing & transportation.
40	Signage	Size: 60 cmX50 cm in plywood fixed Process- Multi colour(Tin plate)

Handwritten signature and date
12/12/2022

41	Tin Plate	Multi coloured Printed Tin Sheet a) Standard Size:910mm x 605mm(5.94 sq. ft) b) Made out of Tin Sheet of 3.00 mm thick as per I.S. 1993/93 c) 5 times pre-printing chemical treatment. d) 4 times multi coloured printing e) Transparent coating and Heat treatment at 200 degree Celsius after each operation. f) Punching Holes of diameter not more than 2mm at each corner and at the midpoint of each size of sheet of Length 910mm are to be provided. All total 6 nos of Punching holes are to be provided in each sheet.
42	Wall Painting	Multi colour painting with Quality & Durable paints (Enamel paints with water proof). It has to prepare a primer coating on the wall before painting.(Rate quoted should be as per sqft)
43	Format/ Forms (Type-1)	Size: A4, Colour: Multi colour, Paper: 70 GSM Maplitho, Single side
44	Format/ Forms (Type-2)	Size: A4, Colour: Multi colour, Paper: 70 GSM Maplitho, Both side
45	Format/ Forms (Type-3)	Size: A4, Colour: Black & White, Paper: 70 GSM Maplitho, Single Side
46	Format/ Forms (Type-4)	Size: A4, Colour: Black & White, Paper: 70 GSM Maplitho, Both Side
47	Format/ Forms (Type-5)	Size: Legal size, Colour: Multi colour, Paper: 70 GSM Maplitho, Single Side
48	Format/ Forms (Type-6)	Size: Legal size, Colour: Multi colour, Paper: 70 GSM Maplitho, Both Side
49	Format/ Forms (Type-7)	Size: Legal size, Colour: Black & White, Paper: 70 GSM Maplitho, Single side
50	Format/ Forms (Type-8)	Size: Legal size, Colour: Black & White, Paper: 70 GSM Maplitho, Both side
51	Format/ Forms (Type-9)	Size: A3, Colour: Black & White, Paper: 70 GSM Maplitho, Single Side
52	Format/ Forms (Type-10)	Size: A3, Colour: Black & White, Paper: 70 GSM Maplitho, Both Side
53	ASHA Incentive Voucher(Assured)	Paper size: 9cm x 20 cm, Quality :70 GSM, One side torn No. of pages per booklet: 36 pages with numbering with ASHA Incentive Sheet Booklet will be supplied in normal binding along with cover page.
54	ASHA Incentive Voucher(other)	Paper size: 9cm x 20 cm, Quality :70 GSM, One side torn No. of pages per booklet: 68 pages with numbering with ASHA Incentive Sheet Booklet will be supplied in normal binding along with cover page.
55	Register (Type-1)	Size: Legal Size, Colour: <u>Black & White</u> , Paper: 70 GSM ,single side, Register:100 pages, Binding: Hard Binding, Side cloth pasting, Side stitch with cover pasting label
56	Register (Type-1-A)	Size: Legal Size, Colour: <u>Multi colour</u> , Paper: 70 GSM , Both side, Register:100 pages, Binding: Hard Binding, Side cloth pasting, Side stitch with cover pasting label
57	Register (Type-2)	Size: Legal Size, Colour: <u>Multi colour</u> , Paper: 70 GSM , Both side, Register:100 pages, Binding: Hard Binding, Side cloth pasting, Side stitch with cover pasting label
58	Register (Type-3)	Size: A3, Colour: Black & White, Paper: 70 GSM , single side, Register:100 pages, Binding: Hard Binding, Side cloth pasting, Side stitch with cover pasting label
59	Register (Type-3-A)	Size: A3, Colour: Black & White, Paper: 70 GSM , both side, Register:100 pages, Binding: Hard Binding, Side cloth pasting, Side stitch with cover pasting label
60	Register (Type-4)	Size: A4, Colour: Black & White, Paper: 70 GSM Maplitho, Single side, Register:100 pages, Binding: Hard Binding, Side cloth pasting, Side stitch with cover pasting label
61	Register (Type-5), ASHA Sector meeting register	Size: A4, Colour: Black & White, Paper: 70 GSM Maplitho, Both side, Register:84 pages, Multi-Colour Offset printing of Front & back cover Binding: Zoo stitching with Thick Hard board((multi board 28 Ozs), Cloth binding at left side of register
62	Register (Type-6)	Size: A4, Colour: Black & White, Paper: 70 GSM Maplitho, both side, Register:100 pages, Binding: Hard Binding, Side cloth pasting, Side stitch with

		cover pasting label
63	Booklet (Type-1)	Size: A4, Colour: <u>Black & White</u> , Paper: 70 GSM Maplitho, <u>Single side</u> , Bookletr:100 pages, Binding: Soft Binding, Side cloth pasting, Side stitch with cover pasting label
64	Booklet (Type-1-A)	Size: A4, Colour: <u>Black & White</u> , Paper: 70 GSM Maplitho, <u>both side</u> , Bookletr:100 pages, Binding: Soft Binding, Side cloth pasting, Side stitch with cover pasting label
65	Booklet (Type-2)	Size: A4, Colour: <u>Black & White</u> , Paper: 70 GSM Maplitho, <u>Both side</u> , Bookletr:10 pages, Binding: Soft Binding, Side cloth.pasting, Side stitch with cover pasting label
66	Booklet (Type-2-A)	Size: A4, Colour: <u>Black & White</u> , Paper: 70 GSM Maplitho, <u>Both side</u> , Bookletr:10 pages, Binding: Soft Binding, Side cloth pasting, Side stitch with cover pasting label
67	Booklet (Type-3)	Size: A4, Colour: <u>Multi colour</u> , Paper: 70 GSM Maplitho, <u>Single side</u> , Bookletr:100 pages, Binding: Soft Binding, Side cloth pasting, Side stitch with cover pasting label
68	Booklet (Type-4)	Size: A4, Colour: <u>Multi colour</u> , Paper: 70 GSM Maplitho, <u>Both side</u> , Bookletr:100 pages, Binding: Soft Binding, Side cloth pasting, Side stitch with cover pasting label
69	Booklet (Type-5)	Size: $\frac{1}{2}$ of A4, Colour: <u>Black & White</u> , Paper: 70 GSM Maplitho, <u>Single side</u> , Bookletr:100 pages, Binding: Soft Binding, Side cloth pasting, Side stitch with cover pasting label
70	Booklet (Type-6)	Size: $\frac{1}{2}$ of A4, Colour: <u>Black & White</u> , Paper: 70 GSM Maplitho, <u>both side</u> , Bookletr:100 pages, Binding: Soft Binding, Side cloth pasting, Side stitch with cover pasting label
71	Booklet (Type-6-A)HBNC Format	Size: $\frac{1}{2}$ Demy , Colour: <u>Black & White</u> , Paper:80 GSM Maplitho, Brightness 77 Minimum <u>Both side</u> , Bookletr:12 pages, Binding: Soft Binding, Side stitch with cover pasting label
72	Booklet (Type-7)HBYC Format	Unit : Booklet, Sheets 30(15 sheets marked as original & 15 Sheet Marked as duplicate)With one carbon sheet in each booklet , size $\frac{1}{4}$ Demy, Paper : Original Sheet White Colour, 75 GSM Maplitho,, Brightness 80 minimum,, Duplicate Sheet(Yellow Colour,54 GSM Maplitho, Binding type : Top pad binding with stapling with hard board on the back side , Cover page , One Cover page on the front (80 GSM Maplitho single side black printed as HBYC Checklist for ASHA) perforation: at the top pf the pad binding (in original sheet of the booklet only)
73	ASHA Grade card (MO DAKHYATA)	Unit: Card Size, $\frac{1}{4}$ Demy, Printing Type : Single side multi-colour, Offset printing , Paper Quality : 160GSM Drawing sheet.
74	Canopy	Foldable/Mouldable Canopy, Size: 6'X6'x7 , Fabric Media(Sample Annexed), The Inner end side of the Canopy to be displayed with different messages.
75	Register (Screening)	Size -Conquest 17"x27' , Pages-200,Printing back to back, Binding: Cloth binding
76	Hand book	Size: A4, Colour : Multicolour, Paper: Executive Bond, Both side printing , Booklet 100 pages, Binding: Soft Binding side cloth pasting , Side stich with cover pasting label.
77	Laminated charts	Size: 3'x2' , Paper: Glossy paper, Printing- Multi colour, Hard lamination
78	Wall Hanging	Size: 3'X2' , Fibre pipe pasting, Top & Bottom.
79	Health Calendar-1	Size of Each Sheet of the calendar: 91x58.5 cm.No of Sheet in Each calendar: 10 Sheet.1 , Paper to be used : 220 GSM Art paper .Colour: Multi colour, Binding: Each sheet both side glossy lamination, Top wire with hanger, Calender must be packet in a strong polythene pack /envelope, Size: 24"x37"
80	Health Calendar-2	Type: Wall hanging, Size: 11.5 inch X 18 inch(Half Demy) Paper to be used : 130 GSM Art paper .Colour: Multi colour offset printing , Binding: Wire-o binding with hanger . 4 pages back to back printing.
81	Mini Hoarding Type 1	Size: 6'X3' , Display Area 6ft X 3 Ft , Display Material: Preferably 18 Gauge printed or painted tin plate ,

		Total Height from inside the ground : 10 ft L iron Angle(2”L iron angle should be used.-Base-(Inside ground) 2 ft inside cement concrete. Above ground(Ground to top) 8 ft .Length : 6ft iron angle(2” L iron angle should be used. Mid joist bar to support display material : 3 ft L iron angle(2 “ L iron angle should be used)
82	Mini Hoarding Type 2	Size: 4X3’ , Display Area 4ft X 3 Ft , Display Material: Preferably 18 Gauge printed or painted tin plate , Total Height from inside the ground : 10 ft L iron Angle(2”L iron angle should be used.-Base-(Inside ground) 2 ft inside cement concrete. Above ground(Ground to top) 8 ft .Length : 4ft iron angle(2” L iron angle should be used.Mid joist bar to support display material : 3 ft L iron angle(2 “ L iron angle should be used)
83	T-Shirt	Colour: White,Sleeve : Half Sleeve.,Sleeve Binding: Rib Knitted fabric. Neck: With Collars with buttons-Blue Collar in White T-Shirt. Neck Binding: Rib knitted fabric. Provision of pockets(Y/N) : No Sizes: S(10-16 Yrs) , M, L, XL , XXL. Material: Polyester- Cotton Mix(50% polyester, 50 % cotton) . Mass (in gm) 200. Anti-Shrink: Yes,Anti-wrinkle: Yes.Logo Marking : As per the buyers requirement.(as per the prototype)Type of logo: Printed. Availability of test report from NAB accredited or central Govt Lab to prove the conformity of the product to the specification: Yes.Test report to be furnished: Yes
84	Peak Cap	Colour: White Material: Barathea Cloth. Adjustable strip: Adjustable strip at the back of the cap. Availability of test report from NAB accredited or central Govt Lab to prove the conformity of the product to the specification: Yes. Test report to be furnished. Agree to provide a sample for buyer’s approval before commencement of supply.
85	OPD Ticket Booklet	Size-A4, Paper - 70GSM .Auto carbon copy, Printing : Colour, Single Side,One Booklet -200 pages(100 pages original copy & 100 pages auto carbon copy)
86	Discharge & referral Slip	Binding: 100 pages in each pad , Size : 26 cm X18 cm, Process: Black & white(single side print) paper : 70 GSM Maplitho, Unit : Per Pad.
87	Pathological investigation form(Blood/Urine)	Binding: 100 pages in each pad , Size : 16 cm X24 cm, Process: bi color(Both side print) paper : 70 GSM Maplitho, Unit : Per book.
88	Money Receipt book (Ambulance/Cabin)	Binding : 200 pages in each book(Original in white & duplicate in Yellow/Pink/Light Blue with Sl no) , Size : 17.5cm X 10.7cm, Process: Black & white (single side print) paper : 70 GSM Maplitho, Unit : Per book.
89	Outdoor/Indoor Register	Size: A3, Process: Black & white (single side print) paper : 70 GSM Maplitho, Binding : Hard Binding ,Side Cloth pasting, side stitch with cover level pasting. Unit: Per book.
90	Attendant pass	Size: 8 cm X 9 cm , Bi- colour, single side print, Unit : Per Piece
91	E-Chart for eye testing	Specification: A4 Paper, 360 GSM, White Paper with Black Letters "E" in different Angles.
92	Signage	Supply & fixing of Bilingual Signage(Odia & English) or only one language. The signage letter will be made with premium quality vinyl sheet of approved colour. Pasted on 3 mm thick aluminium composite panel backing . The signage will be either fixed on the Wall with screw or & double taped or hanged from the false ceiling with the help of hooks & chains complete work.(rate quoted should be as per square inch)
93	Form (Type -1)	Size: A4, Process Black & White (Single Side) , Paper : 70 GSM , Maplitho., Unit : Per form

94	Form (Type -2)	Size: A4, Process Black & White (both side),Paper : 70 GSM , Maplitho., Unit : Per form
95	Form (Type -3)	Size: A4, Process Four Colour (Single side),Paper : 70 GSM , Maplitho., Unit : Per form
96	Form (Type -4)	Size: A4, Process Four Colour (both side),Paper : 70 GSM , Maplitho., Unit : Per form
97	Form (Type -5)	Size: legal , Process Black & white (single side),Paper : 70 GSM , Maplitho., Unit : Per form
98	Form (Type -6)	Size: legal , Process Black & white (both side),Paper : 70 GSM , Maplitho., Unit : Per form
99	Form (Type -7)	Size: legal , Process Four Colour (single side),Paper : 70 GSM , Maplitho., Unit : Per form
100	Form (Type -8)	Size: Legal , Process Four Colour (both side),Paper : 70 GSM , Maplitho., Unit : Per form
101	Form (Type -9)	Size: A3, Process Blak & White (single side),Paper : 70 GSM , Maplitho., Unit : Per form
102	Form (Type -10)	Size: A3 , Process Black & White (both side),Paper : 70 GSM , Maplitho., Unit : Per form
103	Form (Type -11)	Size: A3, Process Four Colour (single side),Paper : 70 GSM , Maplitho., Unit : Per form
104	Form (Type -12)	Size: A3 , Process Four Colour (both side),Paper : 70 GSM , Maplitho., Unit : Per form
105	Register (Type-1)	Size-A4, Process: Black & White (Single Side) Register, 100 pages, Paper: 70 GSM Maplitho, Binding: Hard Binding, Side Cloth pasting, Side stich with cover level pasting. Unit: Per Register
106	Register (Type-2)	Size-A4, Process: Black & White (Both Side) Register, 200 pages, Paper: 70 GSM Maplitho, Binding: Hard Binding, Side Cloth pasting, Side stich with cover level pasting. Unit: Per Register
107	Register (Type-3)	Size-Legal, Process: Black & White (Both Side) Register, 100 pages, Paper: 70 GSM Maplitho, Binding: Hard Binding, Side Cloth pasting, Side stich with cover level pasting. Unit: Per Register
108	Register (Type-4)	Size-Legal, Process: Black & White (Both Side) Register, 200 pages, Paper: 70 GSM Maplitho, Binding: Hard Binding, Side Cloth pasting, Side stich with cover level pasting. Unit: Per Register
109	Register (Type-5)	Size-A3, Process: Black & White (Single Side) Register, 100 pages, Paper: 70 GSM Maplitho, Binding: Hard Binding, Side Cloth pasting, Side stich with cover level.pasting. Unit: Per Register
110	Register (Type-6)	Size-A3, Process: Black & White (Single Side) Register, 200 pages, Paper: 70 GSM Maplitho, Binding: Hard Binding, Side Cloth pasting, Side stich with cover level pasting. Unit: Per Register
110a	Filaria Family Register	Size: A4, Colour: Black & White, Paper: 80 GSM Maplitho, <u>Both side</u> , Booklet :62 pages, Binding: Soft Binding, Side cloth pasting, Side stitch with cover pasting label
111A	SNCU Case Sheet Docket Folder Set:	Each SNCU Case Sheet Docket Folder Set shall contain the following items: 1. Docket Folder with Pocket : Specification : Docket folder with Pocket - Specification: Unit : Nos,Size:9.6"X12"(Folding Size) pages-4+ inside one pocket paper : 350GSM Art Paper (Gloss Finish),Brightness -80 Minimum, Printing : Multi Colour offset printing.(Front & back of the folder) & on pocket)Folding & pasting: One fold& one pocket(12X24 cm) Pasting to contain 10 nos,Sheet Quantity: 1 no

111B		<p>2. Discharge Card : Specification : Discharge Card <u>-Specification:</u> Unit : Nos Size:8.5X11"(Folding Size) pages-4 paper : 120GSM Art Paper (Gloss Finish) Brightness -77 Minimum, Printing : Multi Colour offset printing.(both side) Folding: One fold Quantity: 1 no</p>
111C		<p>3. Neonatal Case Record Sheet : <u>Specification:</u> Unit : Nos,Size:8.5X11"(Folding Size) pages-4 paper : 120GSM Art Paper (Gloss Finish),Brightness -77 Minimum, Printing : Multi Colour offset printing.(both side),Quantity: 1 no</p>
111D		<p>4. Investigating Sheet : <u>Specification:</u> Unit : Nos, Size:8.5X11 pages-2 pages Back to back paper : 90 GSM maplitho, Brightness -77 Minimum, Printing: Bi Colour offset printing. Quantity: 1 no</p>
111E		<p>5. Treatment continuation & Clinical Condition Record Sheet : <u>Specification:</u> Unit : Nos, Size : Size:8.5X11 pages-2 pages Back to back paper : 90 GSM maplitho, Brightness -77 Minimum, Printing : Bi Colour offset printing.Quantity: 3 no</p>
111F		<p>6. Monitoring & nurses Order Sheet : <u>Specification:</u> Unit : Nos, Size : Size:8.5X11 pages-2 pages Back to back paper : 90 GSM maplitho, Brightness -77 Minimum, Printing : Bi Colour offset printing. Quantity: 1 no</p>
112	Consent Form	<p><u>Specification:</u> Unit : Nos, Size : A/4, 8 pages booklet, Colour: Black & White(Both Side) ,Printing with stitching , Paper : 80 GSM , Unit: Per booklet.</p>
113	Delivery Case sheet :	<p><u>Specification:</u> Unit : Nos, Size : A/4,12 pages booklet, Colour: Black & White(Both Side) ,Printing with stitching , Paper : 80 GSM , Unit: Per booklet.</p>
114	Form 4 A, Facility based Neo natal Death Review form :	<p><u>Specification:</u> Size : A/4,12 pages booklet, Colour: Black & White (Both Side) ,Printing with stitching , Paper : 80 GSM ,Unit: Per Booklet .</p>
115	Baby Ticket::	<p><u>Specification:</u> Unit : Nos, Size : A/4,Single Page , Colour: Black & White(Both Side) ,Printing, Paper : 80 GSM , Unit: Per page.</p>
116	Printing of Challan Books under NTCP	<p>Specification: For Enforcement Squads/COTPA Raid, Size: A5, Challan Book is essential. Binding: 200 Pages in each Book (Original in White & Duplicate in Yellow/Pink/Light Blue with Page numbering , Original Perforated</p>
117	Patient Card under NCD	<p>Specifications: Unit: Booklet, Size: ¼ Demy, Total No. of Pages: 20</p>

		Paper:16 pages: 80 GSM Maplitho Paper, Brightness: 77 (Minimum), Both side Single-Colour Printing 4 pages: 90 GSM Maplitho Paper, Brightness: 77 (Minimum) Printing Both side Multi-Colour Printing Binding: Centre Stitching
118	Case Record & Information Sheet for NTCP	Specif: (1) Patient in-take with follow-up Form : (6 pages) (2) Fagerström Scale for detection of level of nicotine dependence (1 Pages) (3) Patient Referral Card (1 Page) (4) Awareness Leaflet (2 Pages) for self Help Tips at Counselling point & FGD Total: 10 pages with Total expected patients.
119	NCD Flip Book: My Health My Responsibility	Specif: Size: 12" x 8", Total No of Flip Sheets: 14 Sheets (28 Pages: Both side count) Paper (Flip Sheets): 300 GSM Art Paper (Gloss Finish), Brightness: 80 (Minimum) Printing (Flip Sheets): Multi Colour both side offset printing. Lamination: Both side lamination of the Flip Sheets. Binding: Wiro Top Binding with 20 mm Wiro Flip Stand Cover: Flip.
120	NCD Drug Paper Pouch	Unit: Envelop, Size: 4.5" x 9" ,Paper: 90 GSM Maplitho Paper, Brightness: 77 (Minimum),Printing: Single Colour Printing (IEC message with Logo)
121	NCD Screening Register	Specif: 200 Pages, Printing Back to Back, Cloth Binding, Size: 17" X 27
122	ASHA Booklet on CBE/SBE And screening of Cervical Cancer	Specif: Size: A4, Colour: Multi Colour, Paper: Executive Bond, Both side printing, 100 Pages Booklet. ANM Job Aids Contain 14 Pages. Binding: Spiral/side Stitching
123	ANM Job Aids	Specif: Size: A4, Colour: Multi Colour, Paper: Executive Bond, Both side printing, 100 Pages Booklet. But ANM Job Aids Contain 4 Pages. Binding: Spiral/side Stitching
124	Patient Referral Cards: For PHC & Sub-Centre level:	Specif: No of Sheets: 50 (50 Sheets Marked as Original + 50 Sheets Marked as Duplicate) with One Carbon Sheet in each booklet. Printing Type (Inner Sheets): Single Side, Black.1st Sheet of the Booklet shall be printed as "Original" and the next sheet shall be printed as "Duplicate" (For taking Carbon Copy) and this will be repeated in the remaining sheets of the Booklet. Paper Size: ¼ Demy. Paper: Original Sheet (White Colour) - 80 GSM Maplitho, Brightness: 80 (Minimum) Duplicate Sheet: (Yellow Colour) - 54 GSM Maplitho .Binding Type: Top Pad binding with stapling with ½ Pound Hard Board on Back Side. Cover Page: 1 Cover page on the Front (80 GSM Maplitho Single sided Black Printing as Patient Referral Card-PHC/Sub-Centre) .Perforation: Perforation at the top of the Pad Binding (in Original Sheet of the Booklet Only)
125	CBAC Forms	Specif: Size: A-4, 70 GSM, Portrait Mode, Single Colour, Normal Paper Double Side Printing in Odia Language.
126	Family Folders (PARIBAR TATHYA)	Specif: Size: Demy 1/4, 70 GSM, Landscape Mode, Single Colour, Normal Paper Single Side Printing in Odia Language
127	Individual Health Cards (Byaktigata Swasthya Bibarani)	Specif: Size: Demy 1/4, 70 GSM, Landscape Mode, Single Colour, Normal Paper Single Side Printing in Odia Language.
128	Flash Card for VIA	Specif: Size: A4, Colour: Multi Colour, Paper: Executive Bond, Both side printing, a Book of 268 Pages..Binding: Spiral/side Stitching
129	Flip Book: For	Specif: Size: 12" x 8", Total No of Flip Sheets: 24 Sheets (48 Pages: Both side count)

	Counselling at Integrated Counselling Centre	Paper (Flip Sheets): 300 GSM Art Paper (Gloss Finish), Brightness: 80 (Minimum) Printing (Flip Sheets): Multi Colour both side offset printing. Lamination: Both side lamination of the Flip Sheets. Binding: Wiro Top Binding with 20 mm Wiro Flip Stand Cover: Flip
130	Cold chain Equipment's Job Card	Size-A5,Type-Both Page,60GSM,Binding with each booklet contains 50 card
131	AVDS weekly reporting form for ILR	Size-A4,Type-single Page,60GSM,Binding with each booklet contains 50 pages
132	JOB Aids for CCP & DVS	Sun Board, Thickness-3mm. Size:3"X5". with fixing
133	District/Block Map for Vaccine Store	Sun Board, Thickness-3mm. Size:4"X8". with fixing
134	ILR AEFI Register	Size: A3, Type-Both page,60 GSM binding with each booklet contain 50 pages.
135	Preventive Maintenance register for CCH	Size-A4,Type-single Page,60GSM,Binding with each booklet contains 50 pages
136	Vaccinator's Logistics Diary	Size: A4 Size Outer Cover Page: 300GSM Glossy Paper- 2 page Multicolour,Inner Cover page:170GSM Glossy Paper-4pages Multicolour Inner Pages:80GSM Xerox paper - 50pages , Black & White
137	Temperature record Book for ILR/DF	Size: A3 Size Outer Cover Page: 300GSM Hard Binding with blue cloth/Rexin corners with end leaves. Inner Cover Page: 170GSM Glossy Paper-1pages Multicolor, Inner Pages: 80GSM Xerox paper - 60pages , Multicolor both side print
138	Physical Stock verification register	Outer Cover Page: 300GSM Hard Binding with blue cloth/Rexin corners with end leaves. ,Size-A4,Type- Both Page,80GSM, Each booklet contains 100 Sheet
139	Visiting Register for CCP	Outer Cover Page: 300GSM Hard Binding with blue cloth/Rexene corners with end leaves. Size-A4,Type- Both Page, 80GSM, Each booklet contains 100 Sheet
140	Name Based Due cum Tally Sheet	Unit: Booklet 100 Sheets: Size: A3 Colour: Black & White, 70 GSM Paper, Maplitho, Both sides
141	Challan Book DVS	Specification : Binding: 150 Pages in each Book , Size : A4(Original in White(perforated) & 2 Duplicate copies in Yellow (perforated)Pink with Page number Stamping 1 to 50
142	Dist VPD Surveillance Booklet (D001)	Hard Binding with Cover page: size: A4, Black & White, D002-4 Pages, D001-52 pages,(White) , 52Perforated(Yellow) (Copy) with 1 to 52 stamping.,
143	Block VPD Surveillance Booklet (H002)	Hard Binding with cover page , size: A4 ,Black & White H001 -1 page, H003- 4 page , H003 A- 4 page, H002- 52 page(White) , 52 Pages(Perforated(Yellow) Copy, With stamping 1 to 52
144	Filaria Patient Card	Size: 14 CM × 22 CM, Process: Multi colour, Paper :130 GSM Maplitho, Single side printing
145	Filaria Flash Card	Size: 11 inch × 8.5 inch, Process: Multi colour, Paper: 250 GSM art paper
146	Dose Pole Chart (Flex Banner)	Size: 6'x 6", Solvent Printing, Fabric Media

Date:
Place:

Signature and seal of the authorized signatory
(Company Seal)

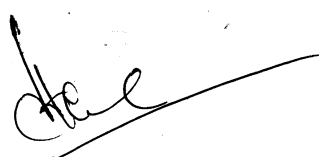

HOARDING STRUCTURE SPECIFICATION (TYPE-1):

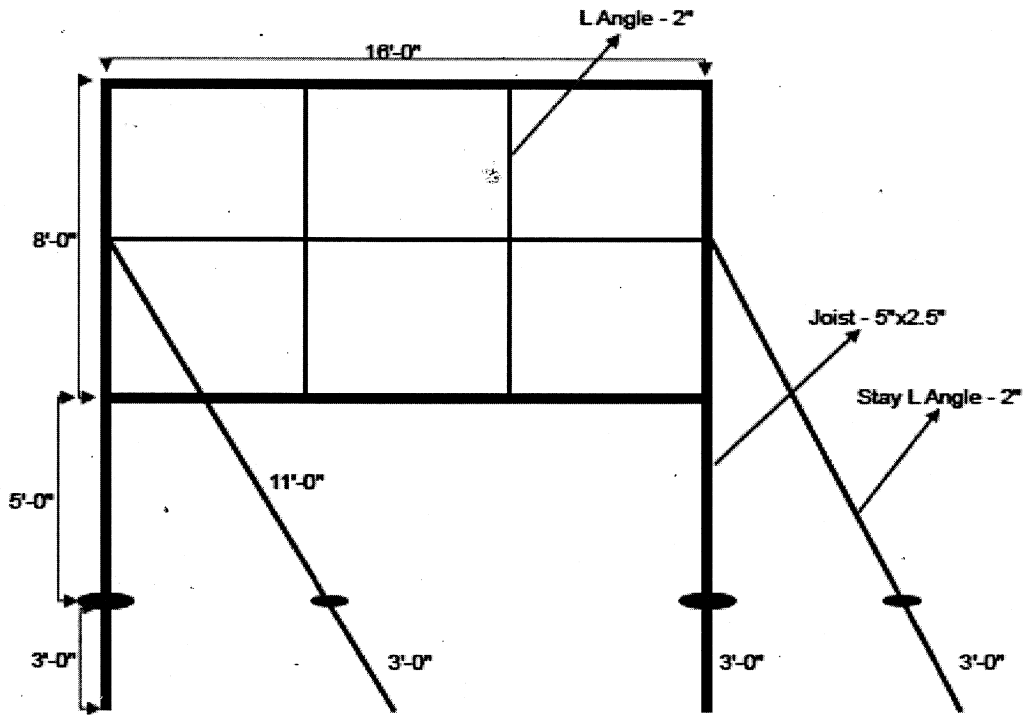

HOARDING STRUCTURE SPECIFICATION (TYPE-2):

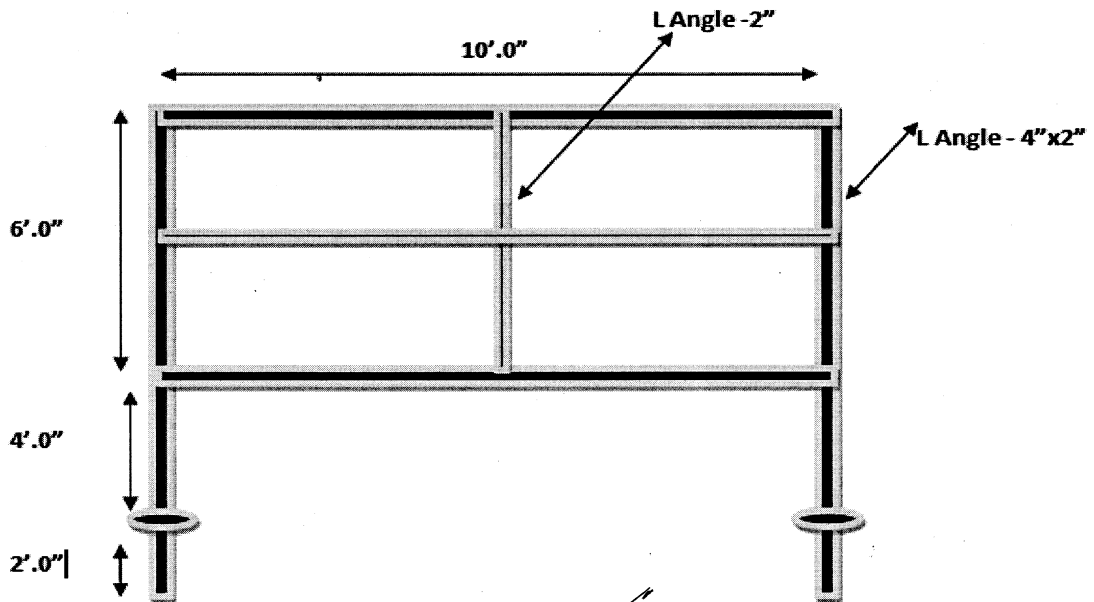

Section-IV

Check List (Technical Proposal) for printing of material

Please check whether following have been enclosed in the respective cover, namely, Technical Proposal: *(please arrange the documents serially in the following order & mention the page no of the tender in box. Without numbering of documents or not mentioning the page nos. in the check list, Tender shall be liable to be rejected.*

Sl no.	Particulars	Submission status (Yes/No)	Page no.	
			From	To
1	Tender Fee (DD of Rs. 1,000/-)			
2	EMD (DD of Rs. 10,000/-)			
3	Copy of the Registration Certificate of the Firm/Company/Agency			
4	Copy of PAN			
5	Copy of the GST registration certificate			
6	Photocopies of Average Annual Turnover 2020-21, 2021-22 & 2022-23) highlighting the turnover in support of that duly certified by Chartered Accountant (As per the format in Annexure-III)			
7	Photocopies of Income Tax Return of each financial year i.e. 2020-21, 2021-22 & 2022-23			
8	Copies of Work Order from the Govt. Organization / PSUs etc. in support of similar works executed during (2020-21, 2021-22 & 2022-23 as per the format in Annexure-IV)			
9	Affidavit of Non-black listed firm for execution of Govt. similar works from notary in non judicial stamp paper of Rs.20/-.			
10	Undertaking for supply of the material as per specification only notary in non judicial stamp paper of Rs.20/-.			
11	Authorization letter of representatives			
12	Copy of tender documents sealed and signed in all pages by the applicant.			

Date:
Place:

Signature and seal of the authorized signatory
(Company Seal)

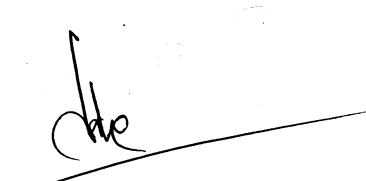

TECHNICAL BID_PRINTING MATERIALS
(to be furnished in the technical proposal)

PROFILE OF THE AGENCY

Name of the Agency	
Office Address	
Status of the Agency	
Name of the authorized signatory & specimen of the authorized signatory	
Telephone Nos.:	Landline :- Mobile :-
Email id	
Registration Certificate of the Firm/Company/Agency	(Furnish copy of the Regd. No. of the Agency)
Income Tax No.(PAN)	(Furnish copy of the PAN no. of the Agency)
GST registration certificate	(Furnish copy of the GSTIN of the Agency)
Tender Fee (DD of Rs. 1,000/-)	DD No: _____/Dt__/_/_____
EMD (DD of Rs. 10,000/-)	DD No: _____/Dt__/_/_____
Annual Turn Over (Format to be attached as per Annexure-III)	2020-21: Rs. 2021-22: Rs. 2022-23: Rs.
Experience in Govt. Sector/ PSUs, etc. (Format to be attached as per Annexure-IV)	
Affidavit of declaration in non judicial stamp paper (On original Stamp Paper)	
Undertaking for supply as per specification in non judicial stamp paper	

Date:
Place:

Signature and seal of the authorized signatory
(Company Seal)

FINANCIAL BID- IEC MATERIALS

SI no.	Name of Items	Specification	Unit of Measurement	Quoted Rate inclusive all freight & charges but exclusive GST (In Rs.)
1	Hoarding (Type-1)	As per Specification	Per Unit	
2	Hoarding (Type-2)	As per Specification	Per Unit	
3	Change of Flex hoarding	As per Specification	Per Unit	
4	Change of Flex hoarding	As per Specification	Per Unit	
5	Poster (Type-1)	As per Specification	Per poster	
6	Poster (Type-2)	As per Specification	Per poster	
7	Poster (Type-3)	As per Specification	Per poster	
8	Poster (Type-4)	As per Specification	Per poster	
9	Leaflet (Tpe-1)	As per Specification	Per Leaflet	
10	Leaflet (Tpe-2)	As per Specification	Per Leaflet	
11	Leaflet (Tpe-3)	As per Specification	Per Leaflet	
12	Leaflet (Tpe-4)	As per Specification	Per Leaflet	
13	Leaflet (Tpe-5)	As per Specification	Per Leaflet	
13-a	Leaflet (Type-5-A)	As per Specification	Per Leaflet	
14	Leaflet (Tpe-6)	As per Specification	Per Leaflet	
14-a	Leaflet (Type-6-A)	As per Specification	Per Leaflet	
15	Folder (Type-1)	As per Specification	Per Folder	
16	Folder(Type-2)	As per Specification	Per Folder	
17	Folder(Type-2 A)	As per Specification	Per Folder	
18	Folder(Type-2 B)	As per Specification	Per Folder	
19	Folder(Type-3)	As per Specification	Per Folder	
20	Folder(Type-4)	As per Specification	Per Folder	
21	Folder(Type-5)	As per Specification	Per Folder	
22	Folder(Type-6)	As per Specification	Per Folder	
23	Folder(Type-7)	As per Specification	Per Folder	
24	Folder(Type-8)	As per Specification	Per Folder	
25	Flex Banner (Type-1)	As per Specification	Per Flex Banner	
26	Flex Banner (Type-2)	As per Specification	Per Flex Banner	

27	Flex Banner (Type-3)	As per Specification	Per Flex Banner	
28	Flex Banner (Type-4)	As per Specification	Per Flex Banner	
29	Flex Banner (Type-5)	As per Specification	Per Flex Banner	
30	Flex Banner (Type-6)	As per Specification	Per Sq.ft	
31	Bill board	As per Specification	Per Bill Board	
32	Invitation-cum-Information Sheet	As per Specification	Per Sheet	
33	Vaccination Card(certificate)	As per Specification	Per Certificate	
34	Sticker (Type-1)	As per Specification	Per Sticker	
35	Sticker (Type-2)	As per Specification	Per Sticker	
36	Sticker (Type-3)	As per Specification	Per Sticker	
37	Standee	As per Specification	Per Standee	
38	Display Board (Type-1)	As per Specification	Per Display	
39	Display Board (Type-1)	As per Specification	Per Display	
40	Signage	As per Specification	Per Signage	
41	Tin Plate	As per Specification	Per Tin Plate	
42	Wall Painting	As per Specification	Per Sq.ft	
43	Format/ Forms (Type-1)	As per Specification	Per Format/Form	
44	Format/ Forms (Type-2)	As per Specification	Per Format/Form	
45	Format/ Forms (Type-3)	As per Specification	Per Format/Form	
46	Format/ Forms (Type-4)	As per Specification	Per Format/Form	
47	Format/ Forms (Type-5)	As per Specification	Per Format/Form	
48	Format/ Forms (Type-6)	As per Specification	Per Format/Form	
49	Format/ Forms (Type-7)	As per Specification	Per Format/Form	
50	Format/ Forms (Type-8)	As per Specification	Per Format/Form	
51	Format/ Forms (Type-9)	As per Specification	Per Format/Form	
52	Format/ Forms (Type-10)	As per Specification	Per Format/Form	
53	ASHA Incentive Voucher((Assured))	As per Specification	Per Booklet	
54	ASHA Incentive Voucher((Other))	As per Specification	Per Booklet	

55	Register (Type-1)	As per Specification	Per Register	
56	Register (Type-1 A)	As per Specification	Per Register	
57	Register (Type-2)	As per Specification	Per Register	
58	Register (Type-3)	As per Specification	Per Register	
59	Register (Type-3 A)	As per Specification	Per Register	
60	Register (Type-4)	As per Specification	Per Register	
61	Register (Type-5) ASHA Sector meeting register	As per Specification	Per Register	
62	Register (Type-6)	As per Specification	Per Register	
63	Booklet (Type-1)	As per Specification	Per Booklet	
64	Booklet (Type-1 A)	As per Specification	Per Booklet	
65	Booklet (Type-2)	As per Specification	Per Booklet	
66	Booklet (Type-2 A)	As per Specification	Per Booklet	
67	Booklet (Type-3)	As per Specification	Per Booklet	
68	Booklet (Type-4)	As per Specification	Per Booklet	
69	Booklet (Type-5)	As per Specification	Per Booklet	
70	Booklet (Type-6)	As per Specification	Per Booklet	
71	Booklet (Type-6-A)HBNC Format	As per Specification	Per Booklet	
72	Booklet (Type-7)HBYC Format	As per Specification	Per Booklet	
73	ASHA Grade card (MO DAKHYATA)	As per Specification	Per Card	
74	Canopy	As per Specification	Per Canopy	
75	Register (Screening)	As per Specification	Per Register	
76	Hand book	As per Specification	Per Hand Book	
77	Laminated charts	As per Specification	Per Chart	
78	Wall Hanging	As per Specification	Per Unit	
79	Health Calendar-1	As per Specification	Per Piece	
80	Health Calendar-2	As per Specification	Per Piece	
81	Mini Hoarding Type 1	As per Specification	Per Piece	
82	Mini Hoarding Type 2	As per Specification	Per Piece	
83	T-Shirt	As per Specification	Per Piece	

Handwritten signature

84	Peak Cap	As per Specification	Per Piece	
85	OPD Ticket Booklet	As per Specification	Per Booklet	
86	Discharge & referral Slip	As per Specification	Per Pad	
87	Pathological investigation form(Blood/Urine)	As per Specification	Per Book	
88	Money Receipt book (Ambulance/Cabin)	As per Specification	Per Book	
89	Outdoor/Indoor Register	As per Specification	Per Register	
90	Attendant pass	As per Specification	Per Piece	
91	E-Chart for eye testing	As per Specification	Per Chart	
92	Signage	As per Specification	Per Sq. inch	
93	Form (Type -1)	As per Specification	Per Form	
94	Form (Type -2)	As per Specification	Per Form	
95	Form (Type -3)	As per Specification	Per Form	
96	Form (Type -4)	As per Specification	Per Form	
97	Form (Type -5)	As per Specification	Per Form	
98	Form (Type -6)	As per Specification	Per Form	
99	Form (Type -7)	As per Specification	Per Form	
100	Form (Type -8)	As per Specification	Per Form	
101	Form (Type -9)	As per Specification	Per Form	
102	Form (Type -10)	As per Specification	Per Form	
103	Form (Type -11)	As per Specification	Per Form	
104	Form (Type -12)	As per Specification	Per Form	
105	Register (Type-1)	As per Specification	Per Register	
106	Register (Type-2)	As per Specification	Per Register	
107	Register (Type-3)	As per Specification	Per Register	
108	Register (Type-4)	As per Specification	Per Register	
109	Register (Type-5)	As per Specification	Per Register	
110	Register (Type-6)	As per Specification	Per Register	
111	SNCU Case Sheet Docket Folder Set:	As per Specification	Per Folder	

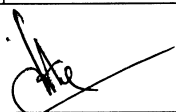

112	Consent Form	As per Specification	Per Booklet	
113	Delivery Case sheet :	As per Specification	Per Booklet	
114	Form 4 A, Facility based Neo natal Death Review form :	As per Specification	Per Booklet	
115	Baby Ticket:::	As per Specification	Per Page	
116	Printing of Challan Books under NTCP	As per Specification	Per Booklet	
117	Patient Card under NCD	As per Specification	Per Booklet	
118	Case Record & Information Sheet for NTCP	As per Specification	Per Sunboard	
119	NCD Flip Book: My Health My Responsibility	As per Specification	Per Sunboard	
120	NCD Drug Paper Pouch	As per Specification	Per Booklet	
121	NCD Screening Register	As per Specification	Per register	
122	ASHA Booklet on CBE/SBE And screening of Cervical Cancer	As per Specification	Per Diary	
123	ANM Job Aids	As per Specification	Per book	
124	Patient Referral Cards: For PHC & Sub-Centre level:	As per Specification	Per register	
125	CBAC Forms	As per Specification	Per register	
126	Family Folders (PARIBAR TATHYA)	As per Specification	Per Booklet	
127	Individual Health Cards (Byaktigata Swasthya Bibarani)	As per Specification	Per Card	
128	Flash Card for VIA	As per Specification	Per card	
129	Flip Book: For Counselling at Integrated Counselling Centre	As per Specification	Per Booklet	
130	Cold chain Equipment's Job Card	As per Specification	Per card	
131	AVDS weekly reporting form for ILR	As per Specification	Per Booklet	
132	JOB Aids for CCP & DVS	As per Specification	Per Sun board	
133	District/Block Map for Vaccine Store	As per Specification	Per Map	

134	ILR AEFI Register	As per Specification	Per register	
135	Preventive Maintenance register for CCH	As per Specification	Per register	
136	Vaccinator's Logistics Diary	As per Specification	Per Diary	
137	Temperature record Book for ILR/DF	As per Specification	Per Book	
138	Physical Stock verification register	As per Specification	Per register	
139	Visiting Register for CCP	As per Specification	Per register	
140	Name Based Due cum Tally Sheet	As per Specification		
141	Challan Book DVS	As per Specification	Per Booklet	
142	Dist VPD Surveillance Booklet (D001)	As per Specification	Per Booklet	
143	Block VPD Surveillance Booklet (H002)	As per Specification	Per Booklet	
144	Filaria Patient Card	As per Specification	Per card	
145	Filaria Flash Card	As per Specification	Per card	
146	Dose Pole Chart (Flex Banner)	As per Specification	Per chart	

Date:

Place:

Signature and seal of the authorized signatory
(Company Seal)



(To be furnished in the letter head of the Auditor/ Chartered Account mentioning the Membership no.)

ANNUAL TURNOVER STATEMENT

The Annual Turnover for the last three financial years of M/s _____ who is a Manufacturer / Supplier (Pl. tick whichever is applicable) are given below and certified that the statement is true and correct.

Sl.No.	Year	Turnover in (Rs.)
1.	2020 - 2021	
2.	2021 - 2022	
3.	2022 - 2023	

Average Annual Turnover (for the above three years) in (Rs.) _____

Date:

Signature of Auditor/ Place:
Chartered Accountant

(Name in Capital)
UDIN No.



ANNEXURE-IV

Format for submission of past performance in govt. sector

Sl. No.	Year	Order No. with Date	Order value	Name of the Organization
1.	2020-21			
2.	2021-22			
3.	2022-23			
TOTAL				

Place: _____
Date: _____

Signature with seal of the Authorized Signatory
Name :
Designation :

